



Mazda RX-8



ZOOM-ZOOM



a sports car redefined

It's revolutionary. It's powerful. It's fun to drive. And it's the only rotary-engined production car in the world.

The stunning Mazda RX-8 will stir your soul and ignite your passion for driving.

Inspired by the innovative RENESIS rotary engine, the Mazda RX-8 is both a design and engineering marvel.

A unique blend of visionary style, turbine-smooth power and razor-sharp handling, with the ability to carry four people in comfort. The Mazda RX-8 will challenge your senses and redefine your expectations of a sports car.

Now that's Zoom-Zoom.

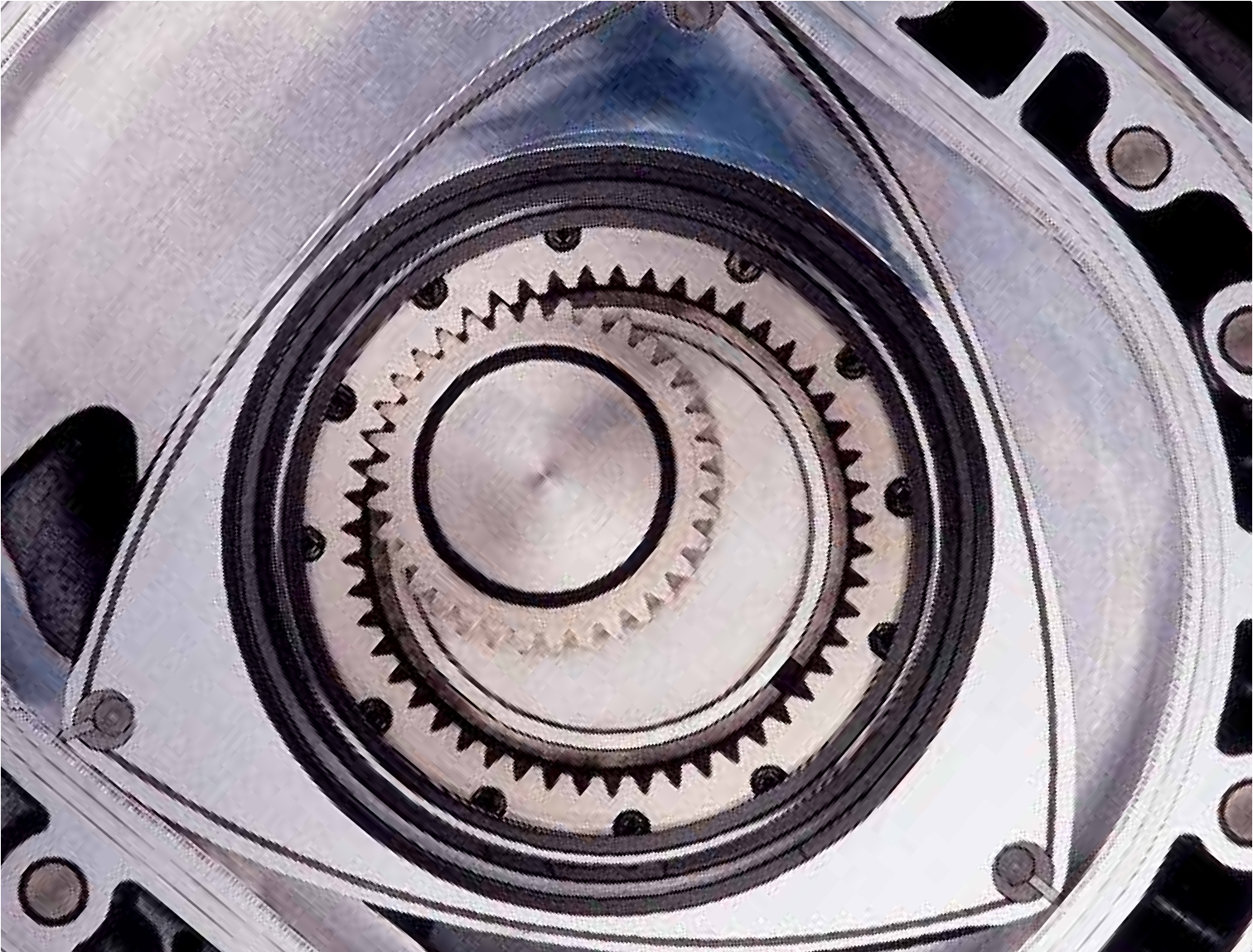

6 Performance revolution

The ultimate rotary engine: RENESIS.

14 A passion for design

Changing the shape of driving.

16 Hidden strengths.

20 Pushing the boundaries

Spaciousness beyond the expected.

26 Freedom of choice

Models, trim levels, options and accessories.

30 Partnership

Mazda services.



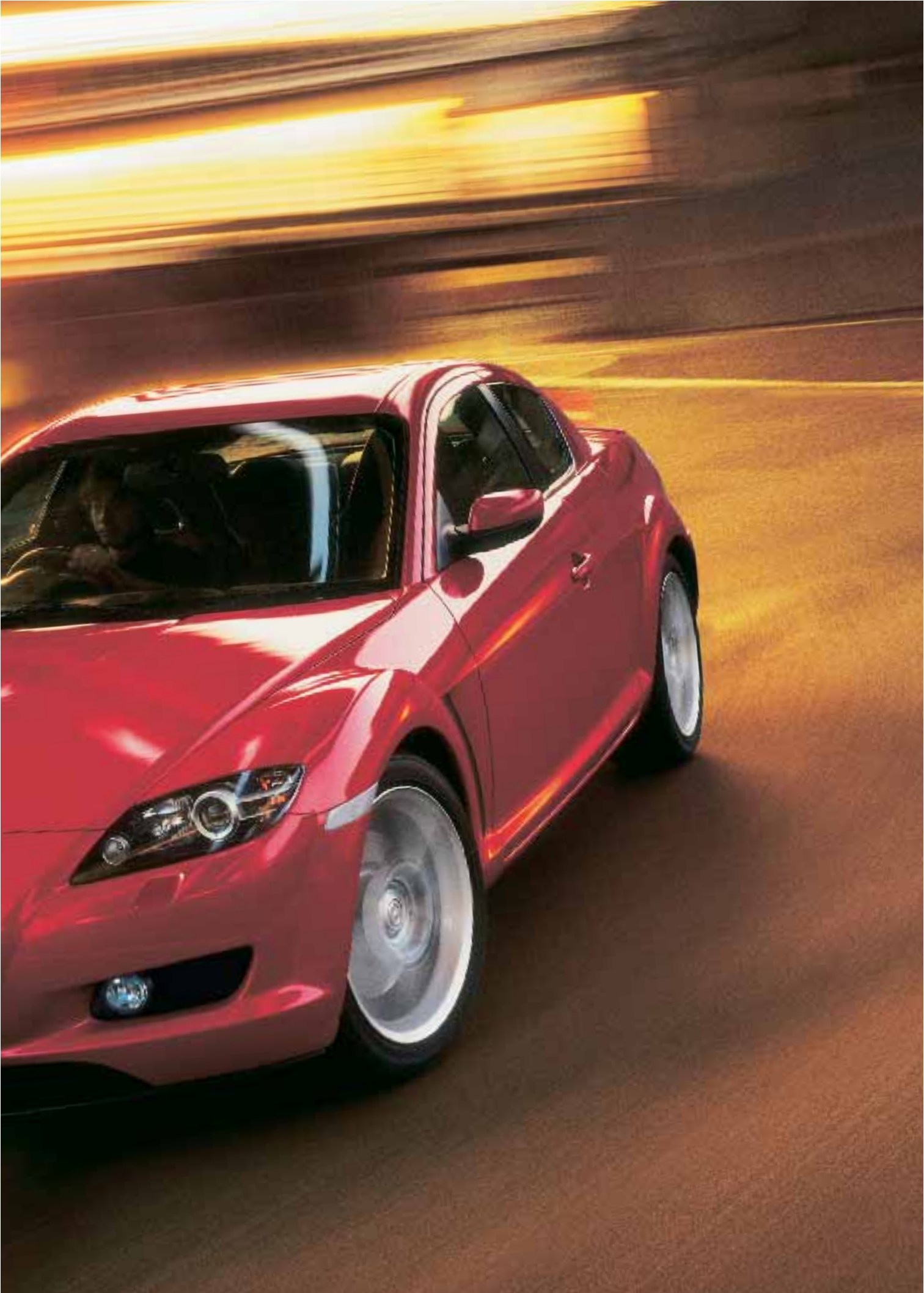



Intake



Compression



Ignition



Combustion

performance revolution

The revolutionary heart that beats inside the Mazda RX-8 began life nearly 80 years ago when a young man, Felix Wankel, had a dream that dared to challenge conventional wisdom. In 1961, Mazda took up the vision and launched a massive development programme into the rotary engine. From that day forward, Mazda has become the acknowledged world leader in rotary engine technology, culminating in the innovative RENESIS engine, which marks the latest chapter of the Mazda rotary engine story.

Unlike a conventional piston engine, the Mazda RX-8's rotary engine has no cylinders, pistons or valves. Instead, two triangular-shaped rotors spin within their oval housings around a common output shaft. As combustion occurs, each rotor instantly turns, and the revs increase rapidly with virtually no vibration. And with only three main moving parts, compared to a minimum of 40 in a piston engine, power delivery is incredibly smooth and refined. With this level of ingenuity, it's no wonder the Mazda RX-8 has won the International Engine of the Year award two years in a row.

There are two RENESIS engines to choose from: the potent 192ps (141kW) engine with a 5-speed manual transmission; and the exceptional 231ps (170kW) engine, coupled to a 6-speed manual transmission. Both engines deliver the kind of smooth acceleration and exhilarating power that will produce an adrenalin rush like you've never experienced before.



Exhaust

The rotary combustion cycle.

In a rotary engine, a triangular-shaped rotor sweeps the fuel/air mixture along, with each part of the combustion process occurring in a different section of the engine housing.

As an apex of the rotor passes the intake port, the fuel/air mixture is drawn in. The intake port is blocked and the mixture is compressed. This compressed fuel/air mixture is then ignited by two spark plugs, ensuring maximum burn and maximum power. The force created by the combustion spins both the rotor and the driveshaft. The rotor's continuing orbit forces exhaust gases out the exhaust port, before the cycle begins again.

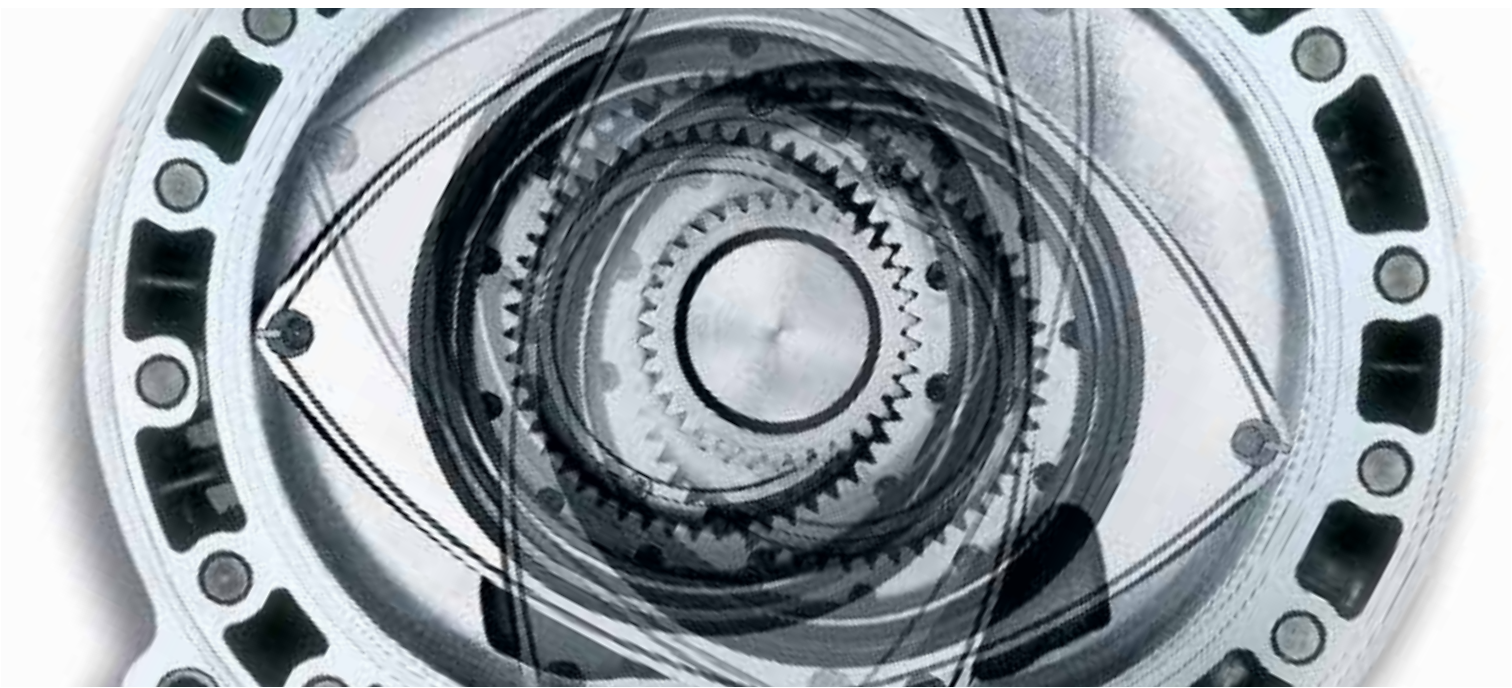



Papenburg automotive proving grounds, Germany, October 2004. Mazda engineers, drivers and technicians celebrated a new 24-hour endurance record. With average speeds of 132.269 and 134.181mph, two Mazda RX-8s drove more than 5,000km on the 12.3km oval track during a 24-hour period to set no less than 40 FIA International Endurance Records. The results clearly demonstrate that Mazda RX-8's revolutionary RENESIS rotary engine not only provides exhilarating performance, but also is durable and reliable even under the most extreme driving conditions.

In 1991, Mazda set the record at the Le Mans 24-hour endurance race. In 2004, they obliterated it with the two Mazda RX-8s.



V6 engine.

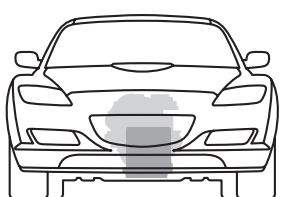

RENESIS rotary engine.

Low centre of gravity.

Lighter and smaller than piston engines of comparable power, the rear-wheel drive Mazda RX-8's rotary powerplant sits lower and further back in the frame, with the fuel tank ahead of the rear axle. Together with the long wheelbase, the result is an impressive power-to-weight ratio, a low centre of gravity and near-perfect 50:50 weight distribution for outstanding agility and stability.

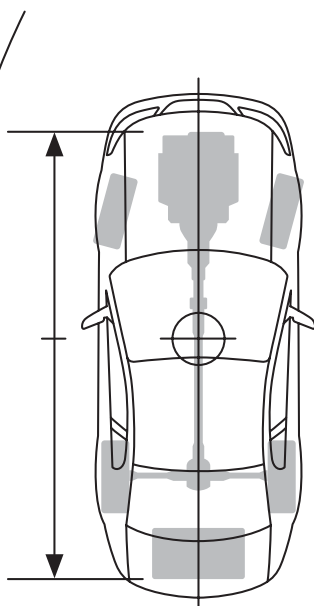

V6 engine.
High polar moment.

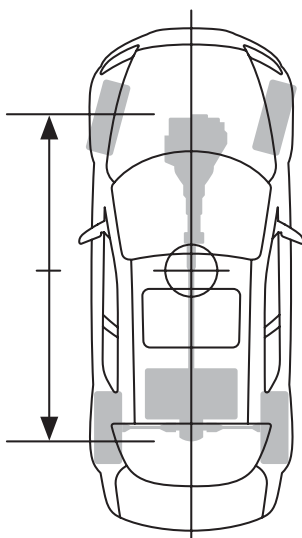

RENESIS rotary engine.
Low polar moment.

Balanced weight distribution.

Uneven weight distribution can significantly impact on a vehicle's stability and handling. So the Mazda RX-8 is engineered to maintain a near-perfect 50:50 weight distribution, regardless of passenger load. The end result is a remarkably agile, well-balanced design.

The centre point is the focus.

Exemplary handling is achieved by positioning much of the Mazda RX-8's mass, including its powertrain and fuel tank, near the car's centre point – its yaw axis. 'Yaw' is movement to the left or right around the vertical axis. As the illustration shows, this gives the Mazda RX-8 a 'low-polar-moment-of-yaw' inertia, making it highly responsive to a change in direction. Cars with widely distributed masses have a 'high-polar-moment-of-yaw' inertia and tend to be less responsive and harder to control.

With an award-winning free-revving rotary engine at its heart, the Mazda RX-8 makes for a truly exhilarating drive. Breathtaking driving dynamics provide the perfect balance of power and stability. From the driver's seat, it means total confidence that the RX-8 will respond as precisely as you expect, delivering its power in a smooth and progressive flow. The result? 100% pure sports car.



The Mazda RX-8's chassis is exceptionally-well balanced. Double-wishbone front suspension and multi-link rear suspension are precision-tuned to provide fluid handling and confident stability around sweeping bends or the tightest of corners. Razor-sharp electric power steering inspires massive confidence, with just 2.9 turns lock-to-lock. For added reassurance, Dynamic Stability Control (DSC) will help to keep you safely on track, working in conjunction with the limited-slip differential to maintain traction during rapid acceleration.

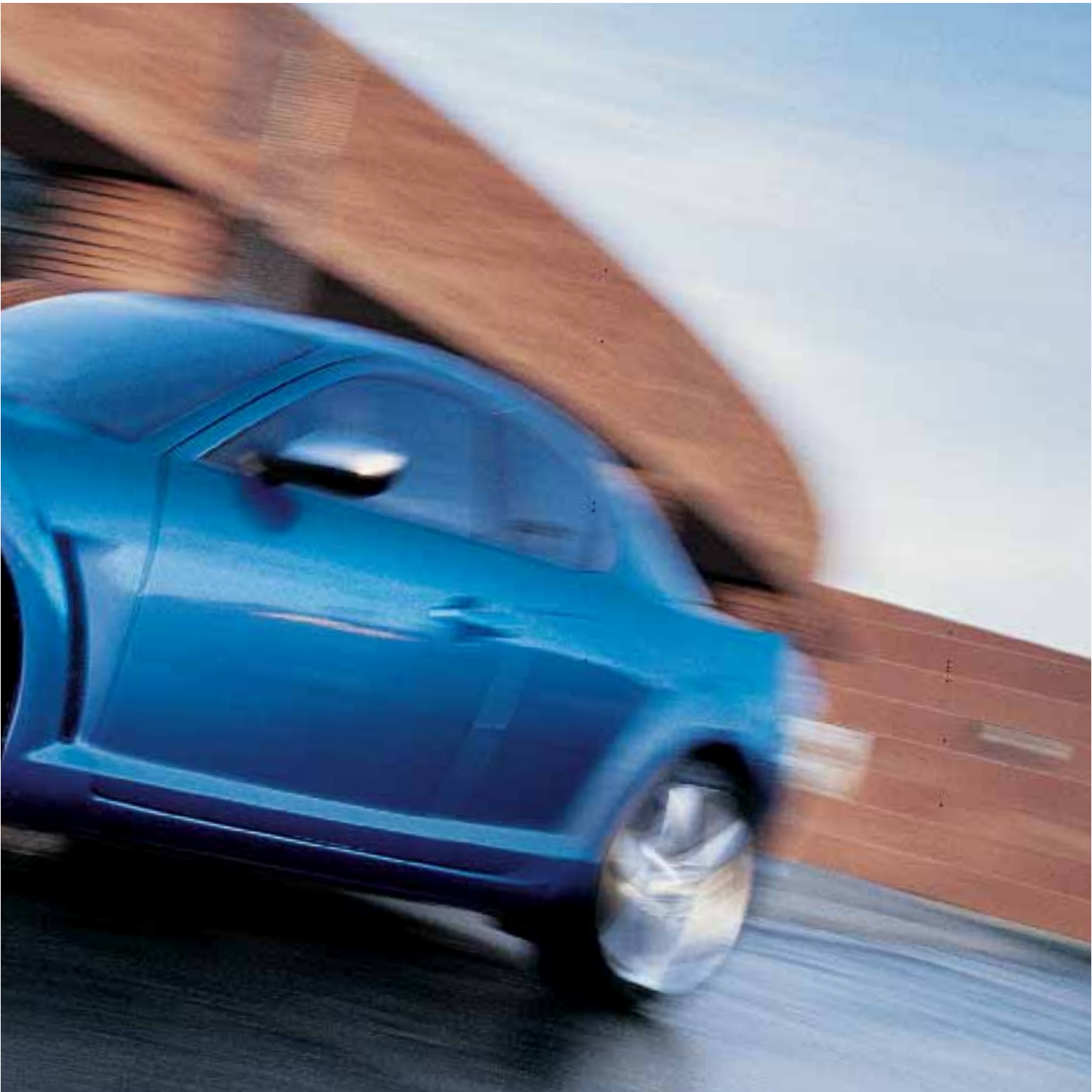

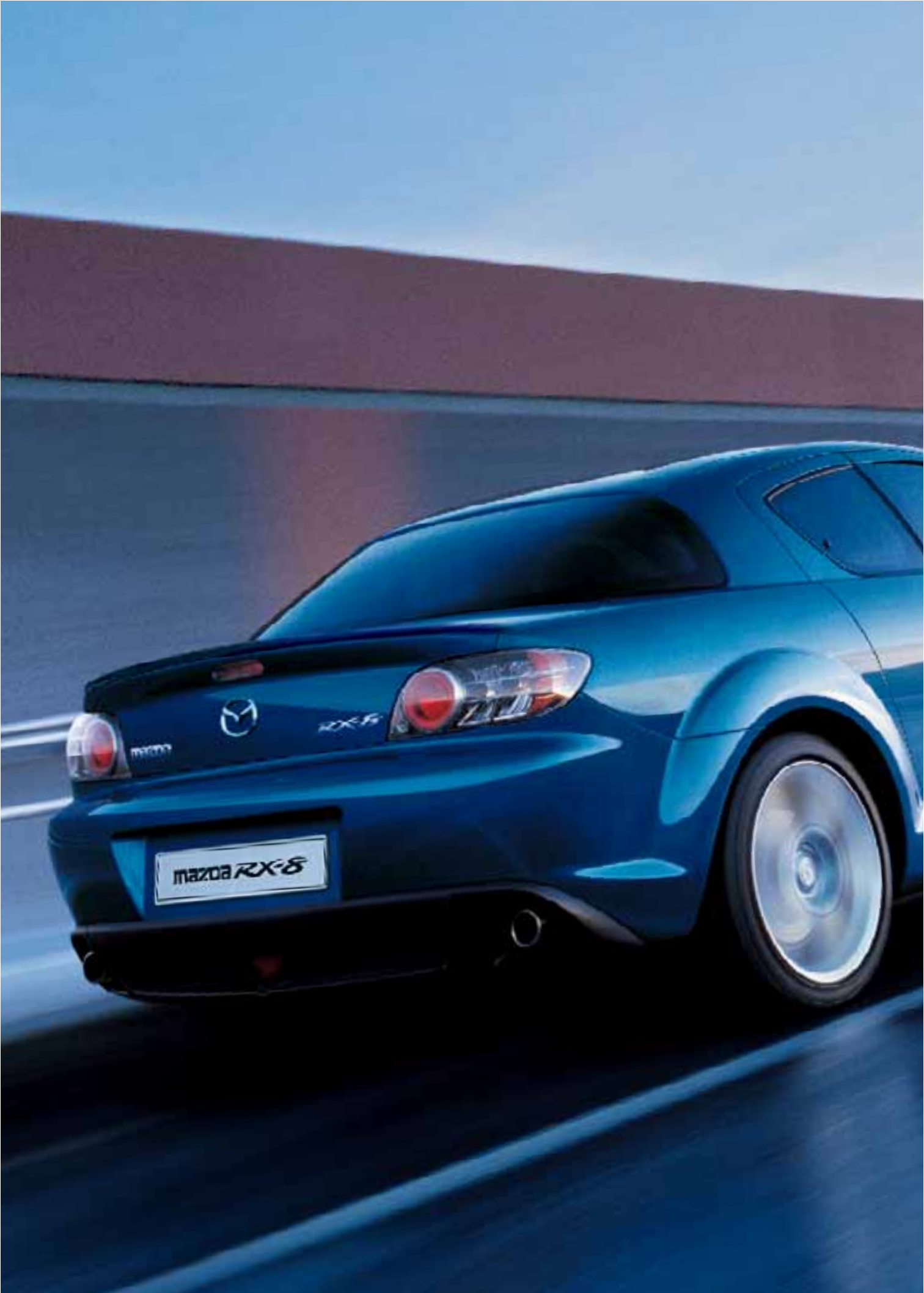





a passion for design



The Mazda RX-8 boldly rejects convention. Like a breath of fresh air, it has brought original thinking into the world of sports coupés. Blending revolutionary 4-door versatility with sleek, aerodynamic styling, this is a beautifully thought-out sports car, designed completely without compromise.

Crouched close to the asphalt, every sensuous curve hints at the power beneath. Flared wheel arches frame the long, elegant bonnet and stretch over the purposeful 18" 5-spoke alloy wheels, placed at the extreme corners of the car for supreme stability and balance. Air outlets behind the front wheels reinforce the RX-8's predatory look, while the rotor's dynamic shape is reflected in the bonnet power bulge and echoed by the rear fog light, flanked by the engine's twin exhaust pipes.

From every angle, the Mazda RX-8 signals its genuine sports car credentials.



The pillar-less, 'freestyle' door system provides exceptionally easy access to the roomy interior. The front and rear doors open from the centre for you and three adult passengers to experience the fun.

The Mazda RX-8's advanced body architecture incorporates MAIDAS, Mazda's Advanced Impact Distribution and Absorption System, to enhance driver and passenger safety.

Ingenious 'freestyle' doors blend 2-door styling with 4-door flexibility, without compromising on safety standards. Extensive reinforcement of the rear doors creates an integrated B-pillar when the doors are fully closed, significantly enhancing body side strength. To continue the coupé styling, the rear door handles are hidden, while the front doors close only after securing the rear doors.

Ventilated 4-wheel disc brakes, enhanced by Anti-lock Braking System (ABS) and Electronic Brake-force Distribution (EBD), provide exceptional feel and make it easy to judge how much power to apply to the pedal to safely scrub off a little speed before entering a corner, or bring the car to a standstill quickly and safely. In addition, Dynamic Stability Control (DSC) and Traction Control (TCS) provide intelligent, reassuring handling by subtly assisting at the limits of grip without diminishing your driving pleasure.



1 3
2 4



- 1 **Cabin reinforcement.**
A ring-shaped structural reinforcement around the door opening in each of the body's side panels improves cabin rigidity. These structural reinforcements result in maximum strength and stiffness. A collapsible brake pedal further helps prevent ankle injury in a front impact.
- 2 **Airbag system.**
Driver and front passenger airbags, as well as side and curtain airbags, help to ensure all-round passenger safety in case of side collisions and also prevent passengers from being thrown from the vehicle.
- 3 **Strengthening V-brace.**
A V-shaped diagonal brace is attached to the top mounting of each rear suspension damper, giving rigid damper support and promoting torsional rigidity at the rear of the body.
- 4 **Door structure.**
A reinforced structure in the front edges of the rear doors forms a virtual centre-pillar that locks into the roof and floor, increasing body rigidity and side-impact protection.







pushing the boundaries

For a dedicated sports car, the Mazda RX-8 is unexpectedly roomy, with plenty of space for the driver and three adult passengers. No matter where you sit, you are sure to enjoy the ride. The low-slung front sports seats have deep, supportive side bolsters and offer an adjustable driving position. In the rear, sculpted front seatbacks free up even more space. All essential controls are well within reach for intuitive operation.



The interior styling is faultless down to the smallest detail. Beautiful leather or cloth trim? The choice is yours. Choose leather and the driver's seat will be power-adjustable, with heated seats for you and your front passenger. Throughout the cabin, cool technical aluminium detailing marks this out as a true sports car, while the rotary design cues continue with a distinctive rotor-shaped gear knob and front seatback apertures.

What you may not expect, however, is the large, easily-accessible boot. With more than 290-litres of luggage space, plus the convenience of a ski-hatch between the rear seats, the Mazda RX-8 will easily accommodate two golf bags or weekend cases.



Settle into the driver's seat, grip the tilt-adjustable leather-wrapped steering wheel and you are in complete control. Instrumentation is precisely where it should be, clearly visible within three deeply-cowled dials, with a tachometer boldly taking centre stage. Set into the dramatic piano-black centre console, a custom-tuned premium Bose® audio system provides entertainment for your listening pleasure. With nine surround sound speakers and a 6-CD in-dash autochanger, it will envelope you in pure, crystal-clear sound.



Not only does the Mazda RX-8 deliver the ultimate in driving enjoyment through its remarkable power, roadholding and handling, it also indulges its passengers in a refined and luxurious environment. From the stylish aluminium interior detailing to the drilled alloy pedals* and the optional DVD satellite navigation system**, each discovered detail serves to heighten your driving pleasure.

*Standard on 231ps model.

**Only available with optional leather trim.

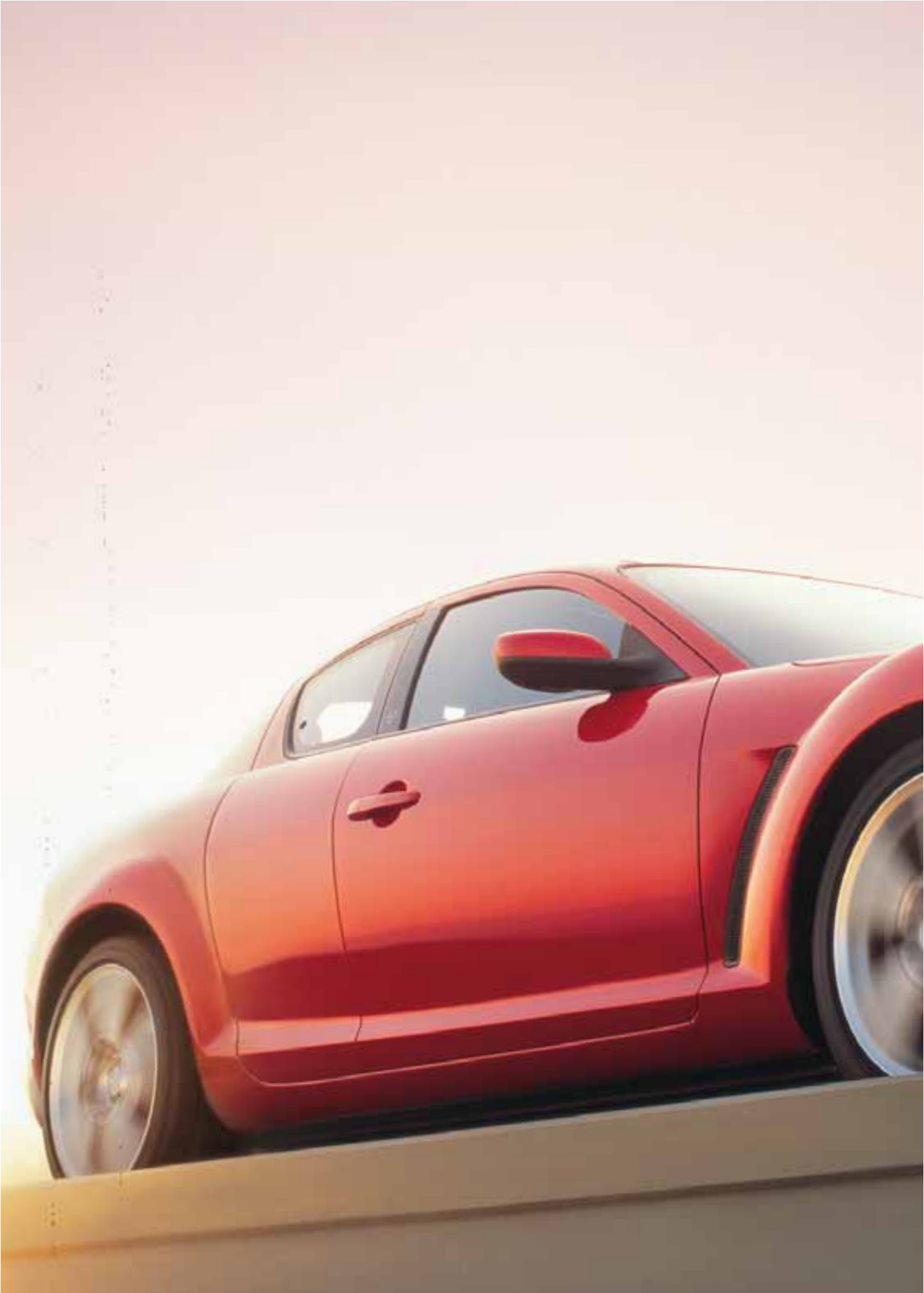





freedom of choice



With two powerful interpretations of the award-winning Mazda RX-8 to choose from, we know it can be tough to decide. But whether you favour the RENESIS 192ps engine or the 231ps version, you can be assured of a genuinely unique sports car, powered by race-proven technology, for those who love the road.

Exclusive high-tech options allow you to reflect your personality in your new Mazda RX-8. Optional equipment includes leather interior trim, a DVD satellite navigation system, electric tilt-and-slide sunroof and metallic / mica paint.

The stunning Mazda RX-8 already stands out from the crowd. But because only you know what you really desire, we have left plenty of scope for you to express your individuality by choosing from a comprehensive range of high-quality accessories.





- 1 Side air dam skirt.
- 2 Front air dam skirt.
- 3 Air outlet fins.
- 4 Brushed aluminium fuel cap.
- 5 B-pillar trim.
- 6 Exhaust trim surround.
- 7 Leather centre console lid.
- 8 Leather gear lever knob with illumination.
- 9 Leather handbrake lever.
- 10 Scuff plate.

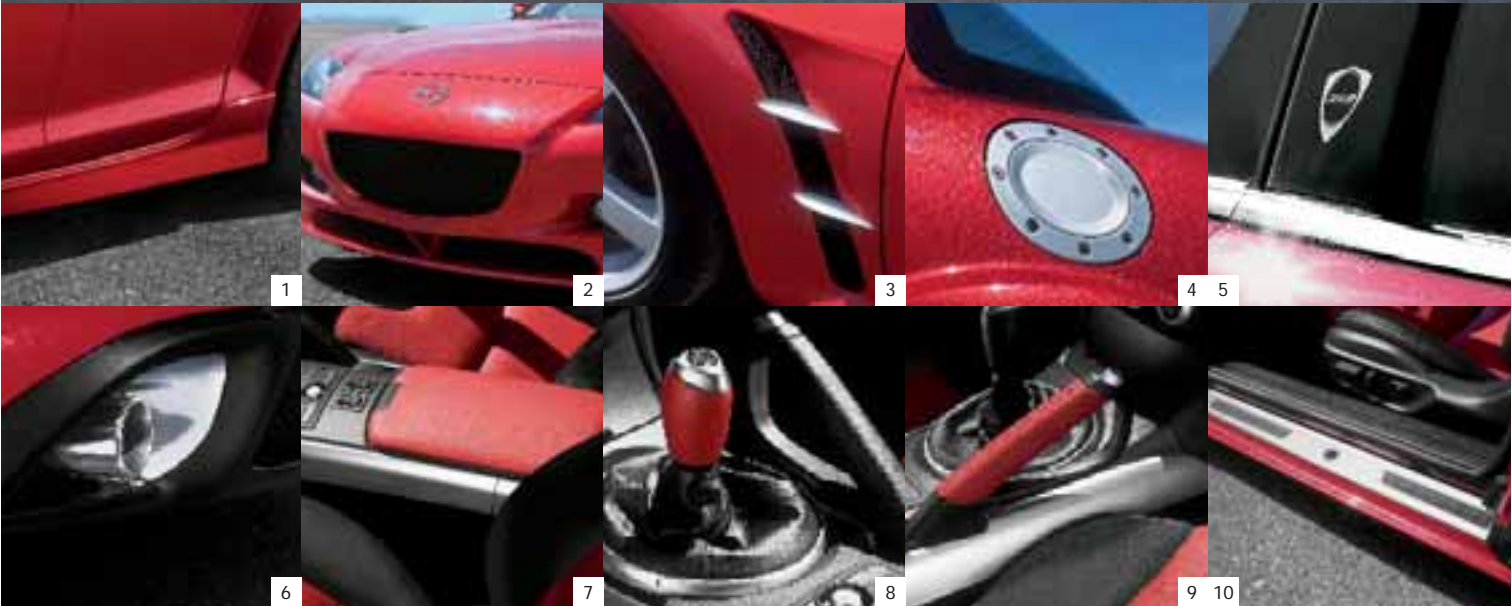

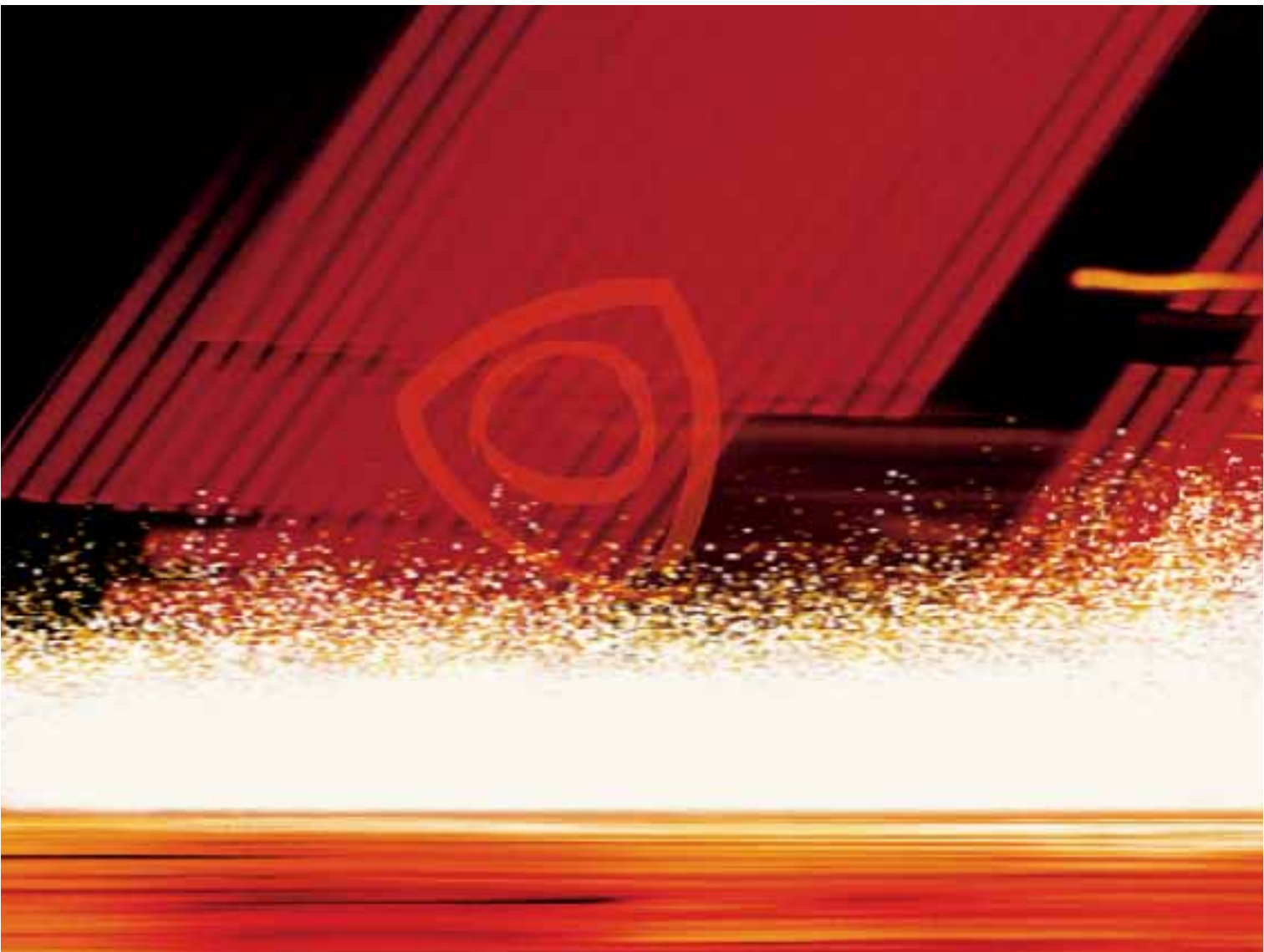

partnership

Mazda Credit for private customers*.

Mazda Credit provides you with the opportunity to drive your new Mazda using either the more traditional Mazda Hire Purchase plan or the flexible Mazda MultiOption plan and Mazda MultiOption Cashplan.

Finance is fast and easy to arrange at your Mazda dealer as all dealers are linked directly online to the Mazda Credit System.



Mazda Insurance**.

Mazda Insurance offers a range of specially tailored motoring related insurance protection, designed to provide you with total motoring peace of mind. Our cover includes Mazda Motor Insurance, Payment Protection Plan and Guaranteed Asset Protection (GAP).

*Finance subject to status. Guarantees / Indemnities may be required. Written quotations: Mazda Credit UK, Central Office, Eagle Way, Brentwood, Essex CM13 3AR.

**Mazda Motor Insurance is underwritten by Zurich Insurance Company, a limited company incorporated in Switzerland. Registered in the canton of Zurich No. 3.749.620.01. UK branch registered in England, No. BR105. Registered Office: Zurich House, Stanhope Road, Portsmouth, Hampshire PO1 1DU.

A member of the General Insurance Standards Council and Financial Ombudsman Service. Telephone calls may be recorded or monitored for training purposes.

Mazda Insurance Payment Protection Plan is underwritten by Norwich Union Insurance Ltd. Registered in England, No. 99122. Registered Office: 8 Surrey Street, Norwich NR1 3NG. Member of the General Insurance Standards Council Norwich Union Life & Pensions Limited. Registered in England No. 3253947. Registered Office: 2 Rougier Street, York YO90 1UU. Both companies are part of the Aviva group.

Mazda Insurance Finance Gap and Invoice Gap are underwritten by Mapfre Asistencia Compania Internacional De Seguros Y Reaseguros SA, 22-26 Prospect Hill, Galway, Republic of Ireland, Registered in Ireland with No 903874.

Authorised and regulated by the Financial Services Authority.





The Mazda Warranties.

3-year new car warranty up to 60,000 miles.

The Mazda new car warranty applies for 3 years up to 60,000 miles, typical wearing parts are not covered by this warranty.

12-year warranty against corrosion breakthrough.

The warranty against corrosion breakthrough lasts 12 years.

3-year paintwork warranty.

The Mazda paintwork warranty lasts 3 years, regardless of mileage. If any problems with the paintwork arise during this period, they will be rectified by a Mazda authorised dealer / repairer, provided the manufacturer is responsible for the defects.

Mazda Digital Service Record

The Mazda Digital Service Record (DSR) system provides increased security against counterfeit service documents and odometer tampering, and makes it easy to keep the service history up to date. Stored on a central database, the DSR replaces the traditional paper service book and ensures a secure, accurate and permanent service history for the life of the vehicle.



Part No. MCAG1063A 10/06 (BJN 303363/UKV1)

Your Mazda dealer:

Mazda Motors UK Limited reserves the right to introduce changes in specification and equipment due to its ongoing product development. Colour and trim samples shown in this brochure may vary from the actual colours because of the limitations of the printing process. It is recommended that you consult your Mazda dealer when referring to these.

October 2006.

Internet: www.mazda.co.uk

Mazda Helpline: 08457 48 48 48